

HART[®] Smart Transmitter Config/Debug System

HK-HART232 Manual

1、 General

HK-HART232 is a HART smart transmitter config/debug system, for use in configuration, debugging, management and maintenance of HART smart transmitter. It can also use in management, configuration HART smart device on-line and monitor the process variable.

HK-HART232 hardware is specially designed for the smart device that fitted for HART[®] protocol. It can transmit/receive HART command via PC or portable computer RS232 serial interface. Provided absolute physical layer interface and need not external power supply.

Because using the experience of HART system configuration and management software prevailing internationally for reference in software. HK-HART232 function is across the board and the configuration is convenient. Therefore, it can meet the need of kinds of customs. It is easy to use the software for the customs familiar with WINDOWS because the software interfaces chosen WINDOWS 95/98-operation system.

Please read manual before using the HK-HART232, so you could easy operate it. If you have any questions or the other problems, please connect with us, we'll reply as soon as possible.

TEL: +86-10-58859884
FAX: +86-10-58859889
HTTP: www.huakong.com.cn
E-MAIL: market@huakong.com.cn

Thanks for your choice.

2、 System Character

2.1 Interface Specifications

- Complete compatible with smart HART products of HuaKong and other companies
- Need not external power supply
- Consumed current less than : 6mA
- Insulate voltage between field instrument and EIA-RS232C interface to less than 500Vdc
- Low leakage current: 10uA (MAX, 35Vdc)
- Standard DB9 series interface connection(with link line)
- Dimension: 84mm×59mm×22mm
- Operation temperature: 0℃ (50℃
- Storage temperature range: -25℃ (+85℃
- Humidity: 90% (do not dew)

2.2 Signal Description

- TXD (pin #3)
- RXD (pin #2)
- RTS (pin #7)
- CTS (pin #8)
- DSR (pin #6)

- DCD (pin #1)
- DTR (pin #4)
- GND (pin #5)

2.3 Block Diagram

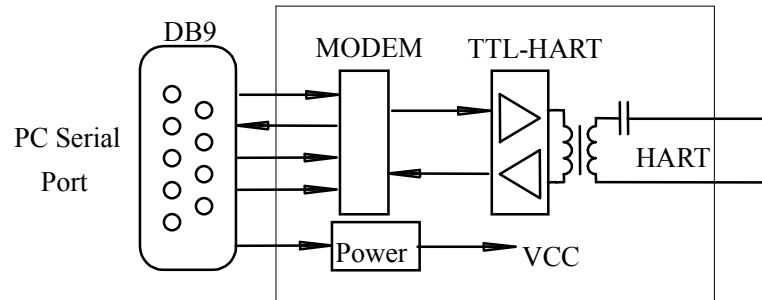

Figure 2.3 HK-HART232 Block Diagram

2.4 Typical Connections

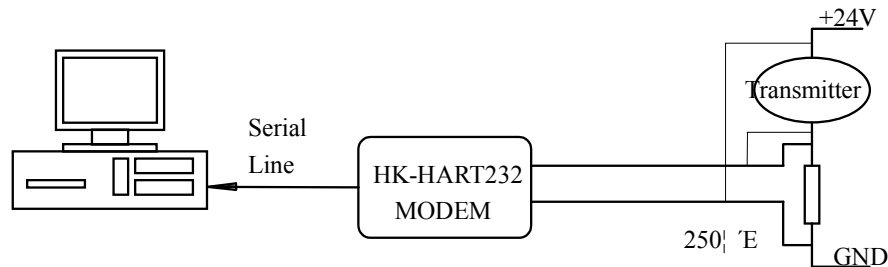

Figure 2.4 HK-HART232 Typical Connections

2.5 Panel

There is two lights on the panel, H1 is power, and H2 show the signal sending.

3、Getting Started

3.1 Minimum System Requirements

- Hardware: 586 or superior PC compatible computer
- Software: WINDOWS 95/98®
- Accessory: mouse、serial interface COM1、COM2、COM3、COM4
- EMS memory: not less than 16M (recommend 32M)
- Require 4M hard disk space

3.2 Installation Procedure

- Make sure you have a CD-ROM
- Place the HK-HART232 Installation CD in your CD-ROM
- Follow the instructions and installs the necessary files on your computer
- Properly connect your field instruments to the interface

3.3 Start HK-HART232

- Make sure that HK-HART232 is connected with the PC serial port
- Click HK-HART232 icon on your table to start the software program

4、 Operation Procedures

4.1 Main Window

The main window screen includes the network window, menu and status bar. The network window is the main operation window for HK-HART232. It has two kinds of operating modes: off-line and on-line Connection.

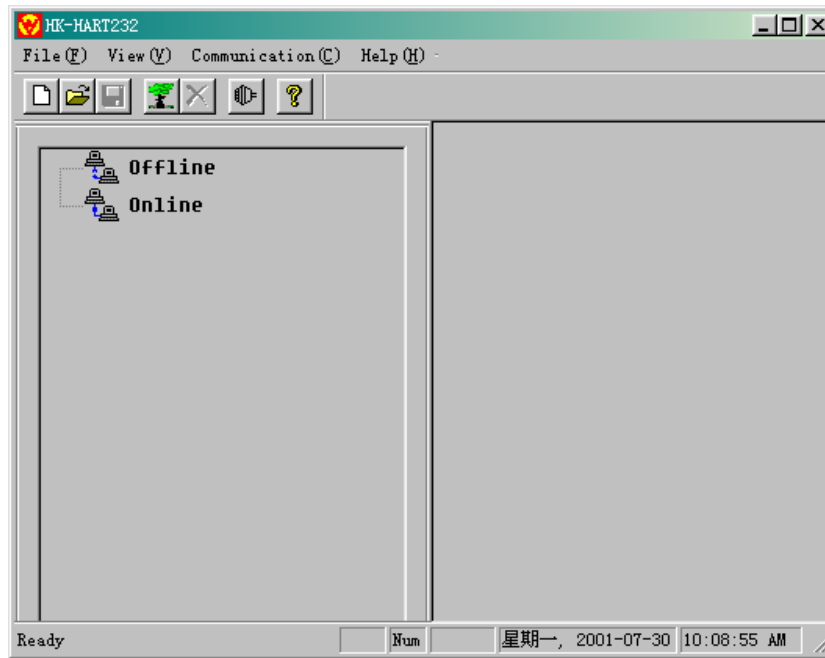

Figure 4.1 Main Window Screen

4.2 Communication Port

Select the Communication Serial Port you wish to use and then click “OK” to process any changes or select “Cancel” to exit this setup window without any changes.

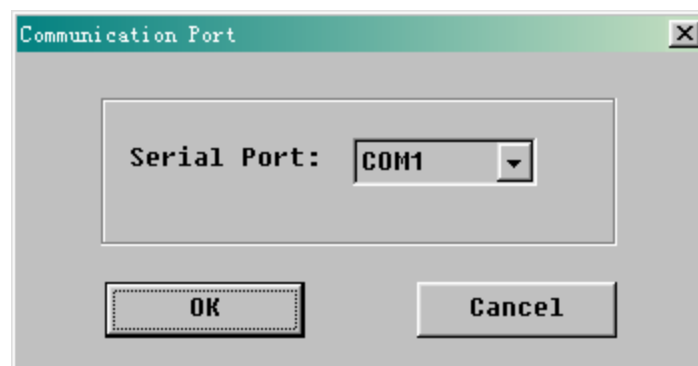

Figure 4.2 Setup Serial Port for Communication

4.3 Online

Click the left mouse button on the sign “+”(“-”) to open (or close) the contents (lists of device) of online connection.

Click the Right mouse button to open the Online Menu.

Use mouse (or up and down arrow keys) to select the online device list. Contents will display all

online device information (tag, device type and address). If there are no contents, then the software cannot find a device connected on the network.

If there is a device connected on the network and there are no contents listed, check the following and then scan the network again:

- a) Device connection;
- b) Network power;
- c) Communication port settings;
- d) Right the address.

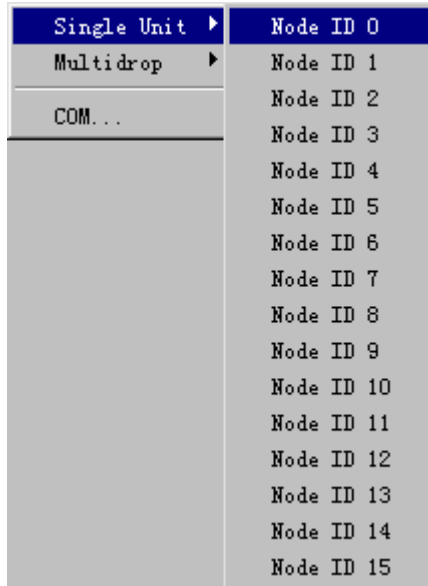

Figure 4.3 Online Menu

Click the Right Button on the listed device to open the Device Menu.

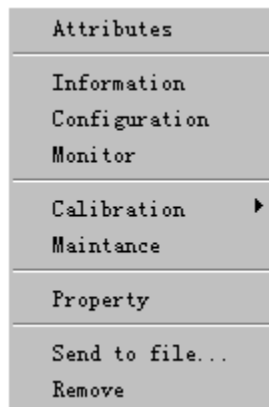

Figure 4.3 Device Menu

4.3.1 Attributes

Attribute Windows display the basic information (Manufacture, Device Type, Tag and Node ID) for the selected transmitter or offline file. The User can change the tag and Node ID (Only for transmitter).

If the device is write-protected, all edit fields will be disabled and in read-only mode.



Figure 4.3.1 Device Attributes Windows

4.3.2 Information

This function allows you to either observe the current values of the information associated with the transmitter or change these values. Variables include the tag, descriptor and data contained within the device.

The tag is an 8 character alphanumeric field for identification of transmitter. The descriptor is a 16 character alphanumeric field for additional identification of the transmitter. In addition, there is a 32 character alphanumeric field that allows you the capability to store an extra message to be contained within the device. This message may be used in any manner best suitable to your needs. However, it is commonly used as complementary information regarding the location and application of the transmitter.

'Send' will process all changes you have made. 'Cancel' will exit without processing any changes.

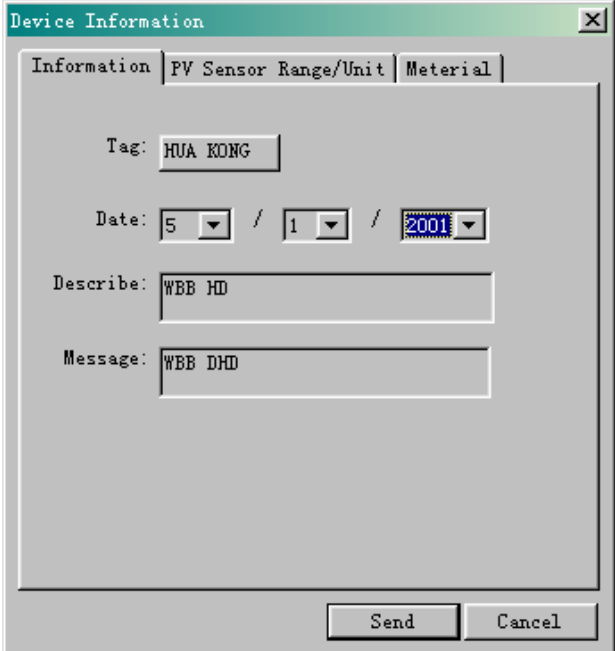

Figure 4.3.2 Information Window

4.3.3 Configuration

This function allows you to display and change the transmitter configuration. There are pages of different categories on the topside of the Configuration Sheet. Select the page to display and access the different categories within configuration.

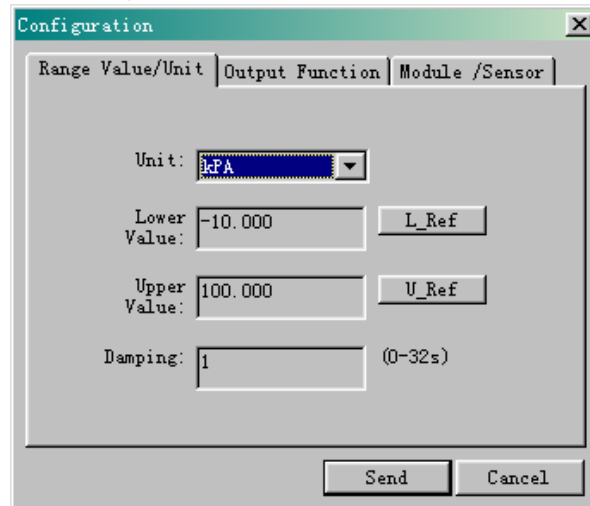

Figure 4.3.3 Configuration Window

4.3.3.1 Range Value/Unit

Read the transmitter range values, units and damping. Send will process all changes you have made. The process variable (PV) will assign 0% of the applied value to the lower value and 100% to the upper value.

The range values will automatically be updated in the new units when the unit definition is changed.

4.3.3.2 Output Function

Read the output function of the transmitter. Send will process all of the changes that you have made.

4.3.4 Monitor

This function enables you to read the currently active selected transmitter variables and to change them. Each slot will accept any transmitter variable code defined by the device. To access and select the available transmitter variable codes, click on the arrow next to the variable

You want to change and click on the one you want to change to.

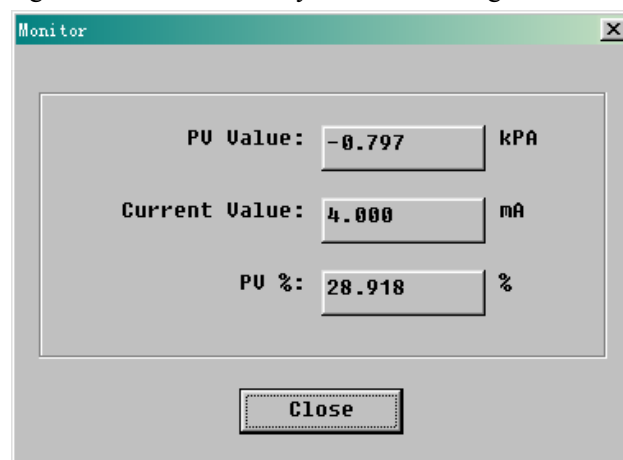

Figure 4.3.4 Monitoring Window

4.3.5 Trim

4.3.5.1 Current Trim

There are two Trim variable options: 4mA and 20mA. First, you must select which Trim Point variable you would like to read and/or change. Once selected, you will see the current value of the associated line current. You are able to change this value by placing the cursor in the field and typing a new value.

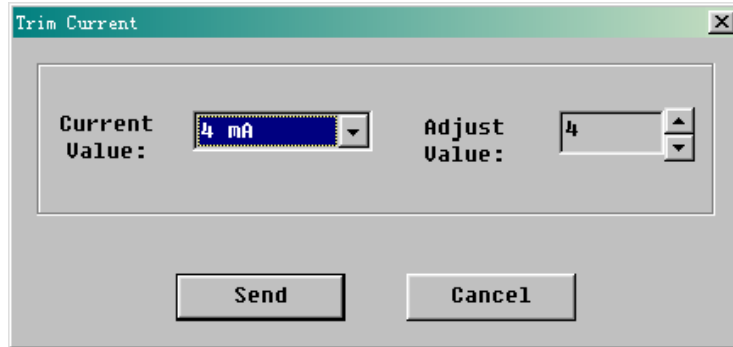

Figure 4.3.5 Current Trim Window

4.3.6 Maintenance

4.3.6.1 Format

This function enables you to read the code number, the final assembly number, the serial number and the device ID associated with the device. These values identify the specific transmitter and are generally used for tracking and reordering purposes. The values should be maintained and updated if any changes are made to the transmitter assembly.

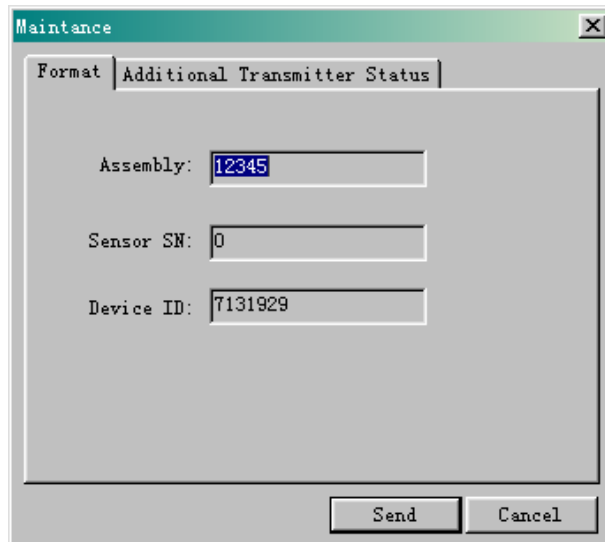

Figure 4.3.6 Maintenance Window

4.3.7 Property

This function reads the Expanded Device Type Code, Manufacturer ID Code, Revision Levels, and Device ID Number. The Combination of Manufacturer ID Code, Manufacturers Device Type

Code, and Device ID Code make up the Unique Identifier required for the Extended Frame Format of the Data Link Layer as described in the HART protocol.



Figure 4.3.7 Property Window

4.3.8 Send to File

This function allows you to create offline files for offline mode. An offline file saves all or part of the data from the instrument into a file. HK-HART232 will default to a file extension of (*.xmt).

4.4 Offline

Click the left mouse button on the sigh “+” (or “-“) to open(or close) the contents of offline connection. The contents will be the file name and tag of a file if one is opened.

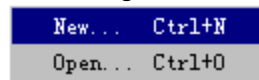

Figure 4.4 Offline Menu

4.4.1 New File

Create new file(*.xmt) for offline mode.

4.4.2 Open File

Open file for offline mode. HK-HART232 will default to look for the file extension (*.xmt) which is the default for files created by HK-HART232.

4.4.3 Save File

Save offline file, if the currently opened file has been changed, with the same name.

4.4.4 Save as...

Save offline file with another file name. It is recommended to keep the default file extensions (*.xmt) assigned by HK-HART232.

4.4.5 Download to...

Download the offline file to transmitter. If online device manufacture ID, device type is same as

the file which current open, download submenu will list all transmitters connected on the network and you can select which device you want to download the current file to. If there is no devices listed in the download submenu, then there is no transmitter on the network or the software cannot find the device which matches the offline file.

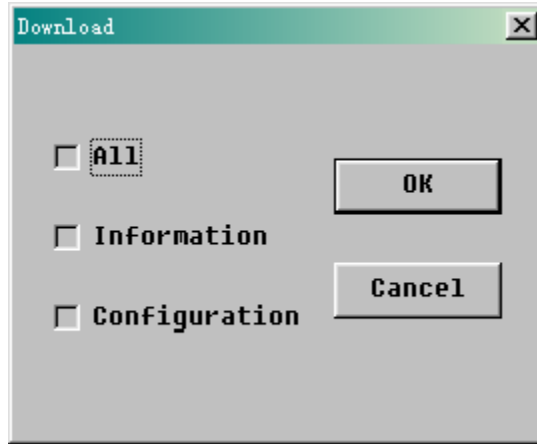

Figure 4.4.5 Download Window

4.5 Help

Help features about HK-HART232 software.

Copyright (1999 by Beijing HuaKong Technology Co., Ltd. All Rights Reserved. No part of this publication may be reproduced, stored in a retrieval system, or transmitted, in any form or by any means, electronics, mechanical, photocopying, recording or otherwise, without prior written permission of the publisher.

The information contained in this document has been checked and is believed to be reliable, no responsibility can be assumed for inaccuracies or changes made to the software. HuaKong makes no warranty for use of the product described in this document. HuaKong does not make a commitment to update the information contained in this document and reserves the right to make changes without prior notice.

A HART Character

@	A	B	C	D	E
F	G	H	I	J	K
L	M	N	O	P	Q
R	S	T	U	V	W
X	Y	Z	[\]
^	_	Space	!	“	#
\$	%	&	‘	()
*	+	`	-	.	/
0	1	2	3	4	5
6	7	8	9	:	;
<	=	>	?		

HART[®] Smart Transmitter Config/Debug System

HK-HART232 Manual

Table of Contents

1、 General	1
2、 System Character	1
2.1 Interface Specifications	1
2.2 Signal Description	1
2.3 Block Diagram	2
2.4 Typical Connections	2
2.5 Panel	2
3、 Getting Started	2
3.1 Minimum System Requirements	2
3.2 Installation Procedure	2
3.3 Start HK-HART232	2
4、 Operation Procedures	3
4.1 Main Window	3
4.2 Communication Port	3
4.3 Online	3
4.3.1 Attributes	4
4.3.2 Information	5
4.3.3 Configuration	6
4.3.3.1 Range Value/Unit	6
4.3.3.2 Output Function	6
4.3.4 Monitor	6
4.3.5 Trim	7
4.3.5.1 Current Trim	7
4.3.6 Maintenance	7
4.3.6.1 Format	7
4.3.7 Property	7
4.3.8 Send to File	8
4.4 Offline	8
4.4.1 New File	8
4.4.2 Open File	8
4.4.3 Save File	8
4.4.4 Save as	8
4.4.5 Download to	8
4.5 Help	9
A HART Character	10